

BX-BAT1 Packing Instruction



Shipper must ensure compatibility with all packaging materials and follow all appropriate transport regulations. For air shipment of liquids, containers must meet pressure, secondary closure and leak-proof liner requirements (See IATA DGR Section 5 / ICAO TI Section 4). Deviations from any part of this instruction may void the UN certification. Please consult 49 CFR for United States record retention requirements, as applicable. More information can be obtained by visiting: www.upwardpackaging.com; or via email: info@upwardpackaging.com

Packaging Components:

- 1 Corrugated Carton (BX-BAT1)
- 1 Liner bag (30" x 30")
- 1 Anti-static bag (18" x 24")
- 2 large inserts
- 4 small inserts
- 3M # 305 48mm clear tape (or equivalent)*

*Sold Separately

Assembly Instructions:

1. Fold flaps on bottom of carton. (See Figure 1)
2. Seal bottom of carton with two strips of 48mm wide, 3M #305 clear packing tape (or equivalent). Extend each strip of tape beyond each edge by at least 2". (See Figure 2)
3. Line carton with included liner bag.
4. Place one small insert at the bottom of the carton. (See Figure 3)
5. Place the two large inserts along the long sides of the carton. (See Figure 4)
6. Place two small inserts along the short sides of the carton. (See Figure 5)
7. Place the battery into the anti-static bag. Seal the anti-static bag with tape.
8. Place the battery into the carton. (See Figure 6)
9. Place the final small insert onto the battery inside of the carton. The battery terminals must puncture the insert. (See Figure 7)
10. Fold the liner bag over the inserts (small edge first) and seal the liner with one strip of tape.
11. Fold flaps on top of carton and seal with two strips of tape. Extend tape beyond each edge by at least 2". (See Figure 8)
12. Mark and label in accordance with appropriate regulations. At least one set of UN markings and both orientation arrows must not be obstructed by hazard labels or other markings.

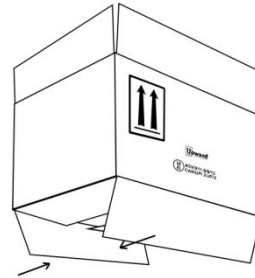

Figure 1

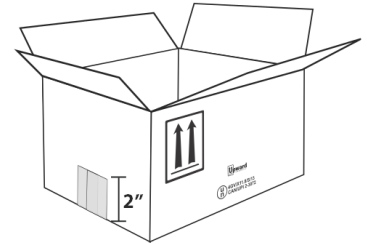

Figure 2

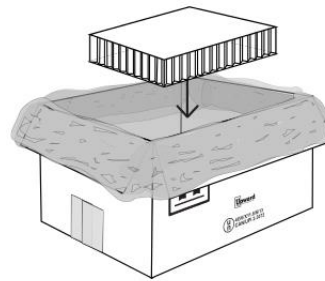

Figure 3

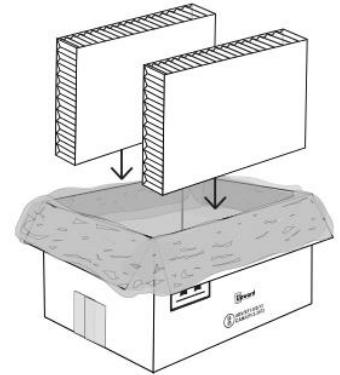

Figure 4

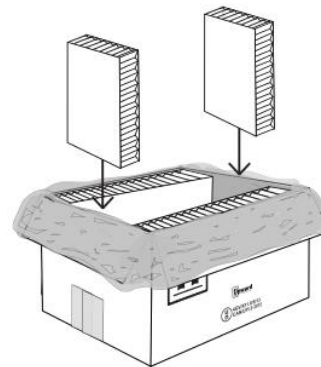

Figure 5

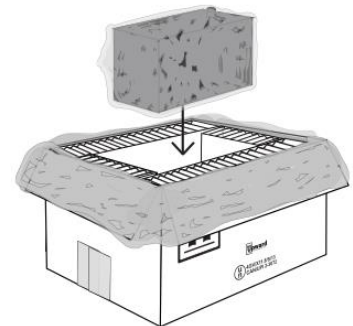

Figure 6

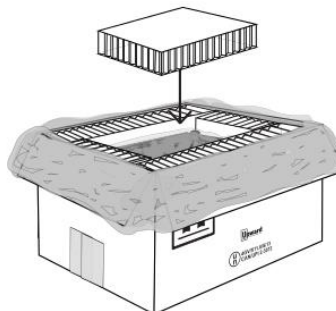

Figure 7

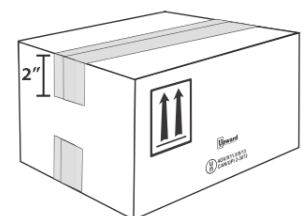

Figure 8

