

# BX-2X1QT Packing Instruction



Shipper must ensure compatibility with all packaging materials and follow all appropriate transport regulations. For air shipment of liquids, containers must meet pressure, secondary closure and leak-proof liner requirements (See IATA DGR Section 5 / ICAO TI Section 4). Deviations from any part of this instruction may void the UN certification. Please consult 49 CFR for United States record retention requirements, as applicable. More information can be obtained by visiting: [www.upwardpackaging.com](http://www.upwardpackaging.com); or via email: [info@upwardpackaging.com](mailto:info@upwardpackaging.com)

## Packaging Components:

- 1 Corrugated Carton (BX-2X1QT)
- 2 1-Quart Cans\*
- 8 Can Clips\* (or 2 Ringlocks\*)
- 3M # 305 48mm clear tape (or equivalent)\*

\*Sold Separately

## Assembly Instructions:

1. Tuck the bottom flaps (long edge first) up to form the bottom of the box. (See Figures 1 & 2)
2. Seal bottom of carton with one strip of 48mm wide, 3M #305 clear packing tape (or equivalent). Extend tape beyond each edge by at least 2". (See Figure 2)
3. Fold down the flaps of the insert and place the insert into the box. (See Figure 3)
4. When filling cans, leave sufficient ullage for expansion.
5. Place the lids on the cans and secure four can clips (or one ringlock) per can. Can clips should be spaced out evenly.
6. Place cans into the inserts. (See Figure 4)
7. Fold flaps on top of carton (long edge first) and seal with one strip of tape. Extend tape beyond each edge by at least 2". (See Figures 5 & 6)

**Note: maximum gross weight of package = 4.2 kg**

8. Mark and label in accordance with appropriate regulations. At least one set of UN markings and both orientation arrows must not be obstructed by hazard labels or other markings.

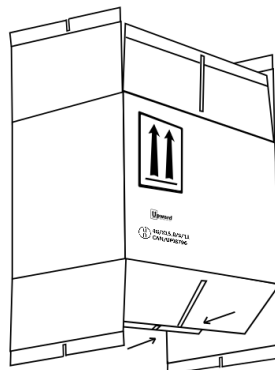

Figure 1

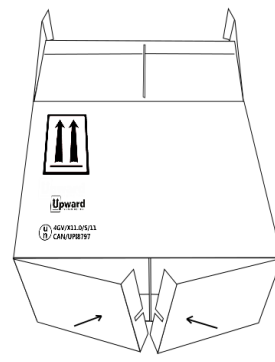

Figure 2

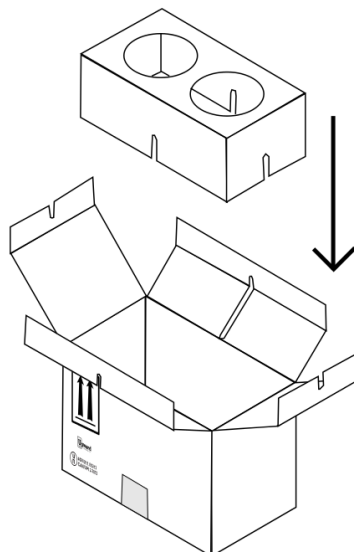

Figure 3

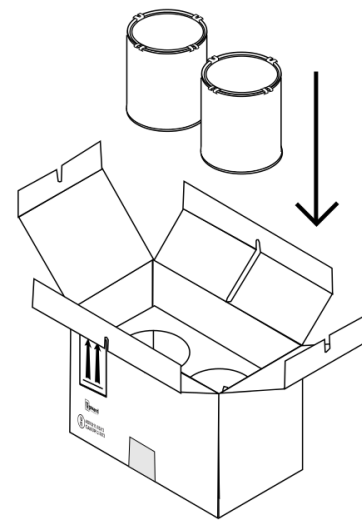

Figure 4

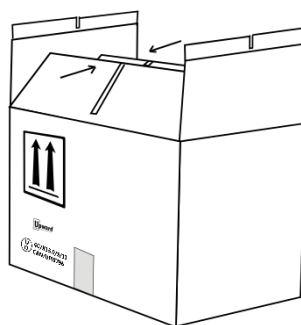

Figure 5

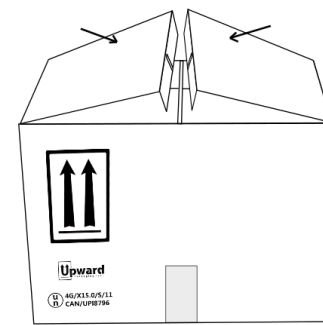

Figure 6

